

HERCULES "LITE"

POWERED STAIRCLIMBER



- Models SAL 110, SAL 140 and Sal 170.
- Fast, professional stairclimbing.
- The world's lightest powered stairclimber.
- Modular aluminium construction.
- Combined powered stairclimber and hand truck.
- Suitable for winding stairs and narrow landings.
- High or low speed operation.
- Pneumatic tyres - dia 260 x 85mm.
- Maximum unladen weight only 16kg (+ snap on battery 4kg).
- 8 optional toe plate sizes to suit many loads.
- Optional foldable frame 1000mm for transport in vans, wagons, cars and hatch backs.
- Optional attachments for white goods, cylinders, water bottles and kegs.



HERCULES "LITE"

POWERED STAIRCLIMBER MODELS

ERGO

On stairs you operate with a straight back and good control over the load, although the load-centre should not be too low. Perfect for parcels, crates, bottles and boxes.

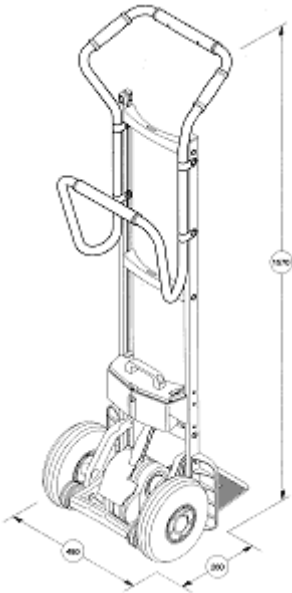

UNI

Typically used for high loads but also popular for smaller loads of different sizes. Looks very much like a normal handtruck.

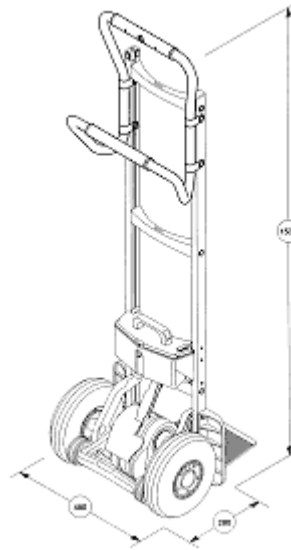

FOLD

With the FOLD you also operate with a straight back because the handle adjusts to the load. Used typically for white goods, vending machines, stoves, boxes, oxygen (gas) cylinders, fruit, tools, wood, tiles etc.

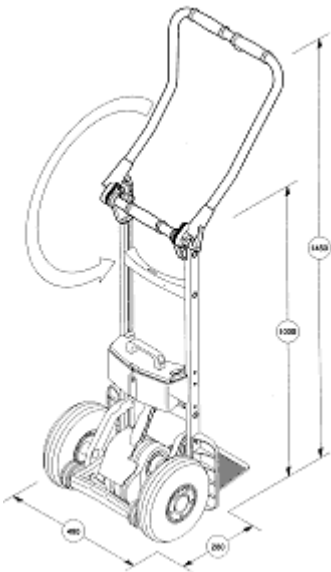

FOLD-L

With the handle in the folded position the stairclimber looks like an ordinary handtruck. In the upright position you are able to accommodate high loads. With the handle in forward position you have got more or less an ERGO.

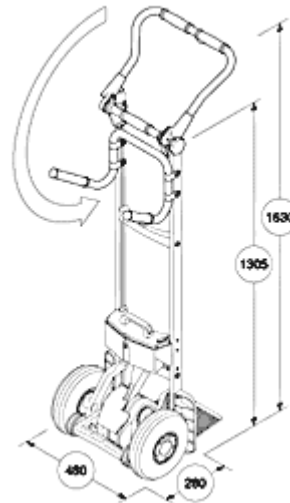

DRIVE - 3 motor-versions to choose from:

- 110kg 48 steps per min
- 140kg 35 steps per min
- 170kg 29 steps per min



HERCULES "LITE"

POWERED STAIRCLIMBER TECHNICAL DATA



- Extremely light: weighs 16 kg plus 4 kg for the snap on battery.
- Very fast: up to 48 steps/minute.
- 2 speed operation: high/low.
- Intelligent power pack features step sensing and starts automatically (descend mode).
- Toeplate hinged – fixed as an option.
- With sliding clutch and electronic overload protection.

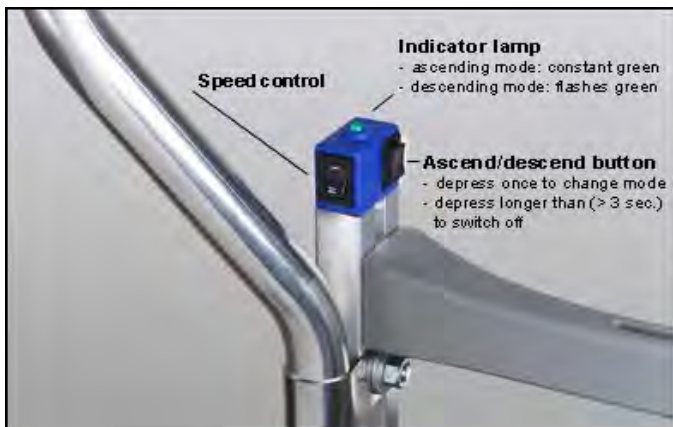

- Handtruck and powered stair-climber combined in one machine.
- The best on winding stairs and narrow landings.
- Large comfortable pneumatic tyres $\varnothing 260 \times 85$ mm.
- With a second battery or the mobile charger the Hercules Lite can be operated all day long. (The battery capacity depends on the load and battery condition – the average is 200-300 steps ascending. Descending at least double).

SPECIFICATION

| Model | | SAL 110 | SAL 140 | SAL 170 |
|---------------------------------------|------------------|-----------|-----------|-----------|
| Capacity | (kg) | 110 | 140 | 170 |
| Maximum climbing speed | per min. (steps) | 48 | 35 | 29 |
| Maximum step height | (mm) | 210 | 210 | 210 |
| Overall height - Ergo | (mm) | 1570 | 1570 | 1570 |
| Overall height - Uni | (mm) | 1530 | 1530 | 1530 |
| Overall height - Fold | (mm) | 1000/1450 | 1000/1450 | 1000/1450 |
| Overall height - Fold L | (mm) | 1305/1630 | 1305/1630 | 1305/1630 |
| Overall width | mm) | 480 | 480 | 480 |
| Overall depth (hinged) | mm) | 275 | 275 | 275 |
| Standard toe depth | mm) | 236 | 236 | 236 |
| Weight - excluding snap on battery | (kg) | 16 | 16 | 16 |
| Weight - including snap on battery | (kg) | 20 | 20 | 20 |
| Battery Capacity - full load (approx) | (steps) | 200 | 300 | 300 |

HERCULES "LITE" POWERED STAIRCLIMBER TOE PLATES

Toeplate Standard

- 275 x 236 x 7 mm
- with grooves against sideways movements

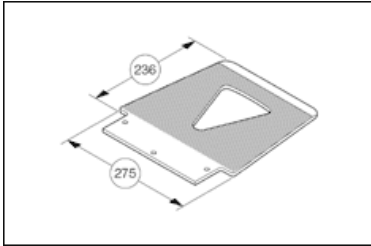

Toeplate G

- 420 x 340 x 7 mm
- for large parcels

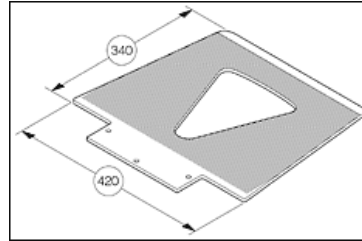

Toeplate GS

- 476 x 239 x 7 mm
- used in the beverage industry - wide enough for the secure transport of kegs and crates

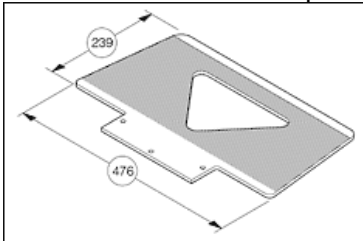

Toeplate WL

- 356 x 180 x 7 mm
- for white goods, cans, crates

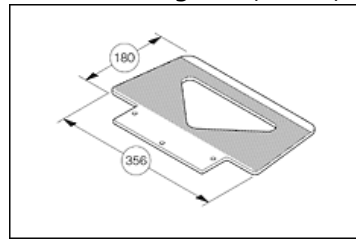

Toeplate XWL

- 590 x 180 x 7 mm
- also white goods (feet on the plate)

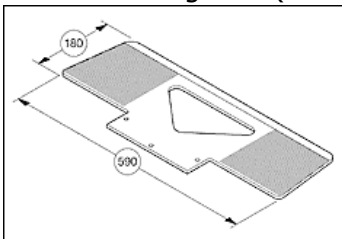

Toeplate DS-NG

- 450 x 190 x 7 mm
- also for goods in cartons

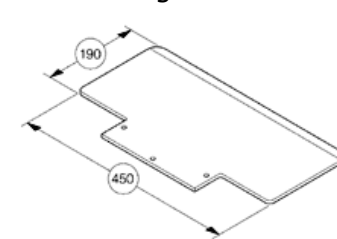

Toeplate GS-NG

- 476 x 239 x 7 mm
- for goods in cartons (like tins or cans)

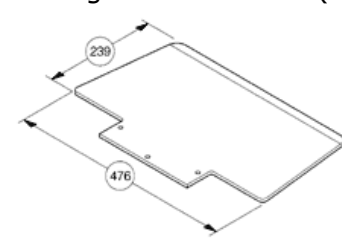

Toeplate V

- 413 x 233 x 5 mm
- mainly transportation of oxygen cylinders

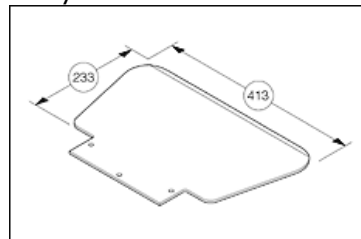

Toeplate LH

- 467 x 278 x 5 mm
- like plate V, but bigger

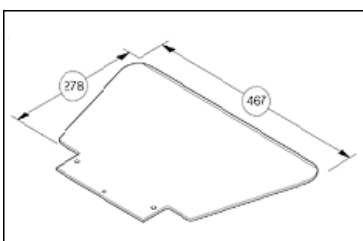

Toeplate for tote boxes

maximum width of 550 mm
Upstanding sides prevent boxes from sliding sideways 40mm high pads cause a slight leaning back of the Lite so that boxes lean against the frame. As a fixed toeplate with pads (without pads this toeplate can be hinged).



HERCULES "LITE" *POWERED STAIRCLIMBER OPTIONS*

Fixed toeplate-attachment
(instead of hinged)

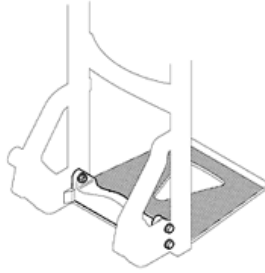

Grey pneumatic tyres
Non marking, 1 pair, blue hub



Puncture proof tyres, grey
1 pair, blue hub



Wheel base extension
80 mm wider, 1 pair



Wings for white goods
length 334mm, 1 pair



Wings long
length 860 mm,
for ERGO, UNI
and FOLD-L



Bar, centre support
flat back, for UNI/ERGO



Bottle water attachment
for 6 bottles, mounted consisting
of a special fixed toeplate for
2 bottles or cooler/boxes and
4 foldable trays



Centre bar with add. crossbar
UNI, ERGO



HERCULES "LITE" *POWERED STAIRCLIMBER*

Mobile Charging

Mobile charger BC 10-30 VDC-SAL



Battery holder with charger

incl. mobile charger
BC 10-30 VDC-SAL



Battery holder flat with charger

incl. mobile charger
BC 10-30 VDC-SAL
battery vertical, space-saving



Double battery holder with charger

incl. mobile charger
BC 10-30 VDC-SAL



Accessories

Extra battery unit BU-SAL

24 VDC, 5 Ah, blue



Extra charger BC 100-230 VAC



Accessories

Folding table

platform 600 x 590 mm
height 600 mm
incl. mounting parts
only applicable with
toeplate WL (356x180mm) or
XWL (590x180mm) hinged
or fixed



Detachable Lifting Frame



Twin bottle holder 204mm



Keg hook



Strap SP-SAL - 1,40 m
(25 mm width)

Strap SP-SAL - 2,70 m
(25 mm width)



Strap SP-SAL - 3,20 m
(50 mm width)

